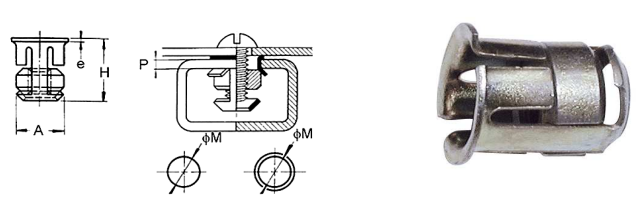

Insert cylindrique à clipper		acier zingué	
			
Ø vis	ØA	H	Plage de serrage
M5	7,2	9,2	0,7 - 3,0
M4	10,1	13	0,7 - 4,0
M6	10,1	13	0,7 - 4,0
M8	13,1	18,2	1,0 - 6,0